

Atlantic

Premium Shutters®

General Guidelines for Installing Traditional Shutters



To deflect rain away from the structure, Louvered shutters should be installed so the louvers face AWAY from the structure when shutters are closed. (see diagram at right)

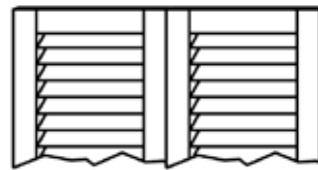

Shutters in closed position

1. Pick shutters to fit window and put next to each window on top of saw horses to make sure shutters are paired properly. Lay two shutters face down next to each other and prepare to install hinges.



2. Install hinges after determining offset. Hinges are to be set at top and bottom even with outside. Drill holes with 1/8th pilot bit. Be careful not to drill all the way through shutter.



3. Position and install upper holdback clips 1" from top and center edge of stile. Shutters over 58" require sets of acorns; install similarly at top.



4. Install slide bolt. Turn shutters over and line-up slide bolt edge with shutter edge (see diagram at right). Pre-drill 1/8 slot hole (careful not to drill all the way through). Install slide bolt with screws. Shutters are now ready for installation.

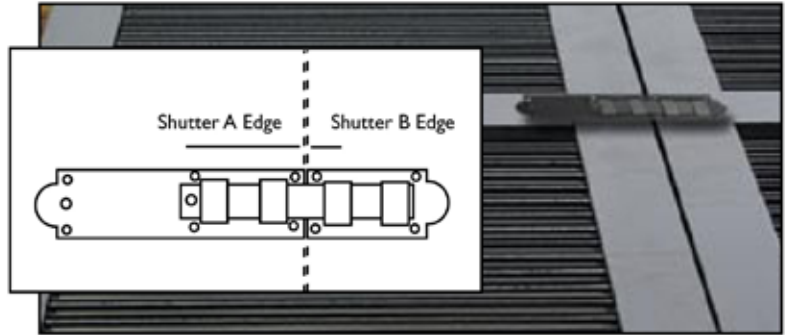

5. Position shutter in opening allowing equal amounts of space between shutter and wall (A, B), and between shutters (C) to allow for smooth operation (see diagram at right). When attaching the pintel to the structure you may have to drill into mortar and brick, use appropriate molly's in mortar and brick.

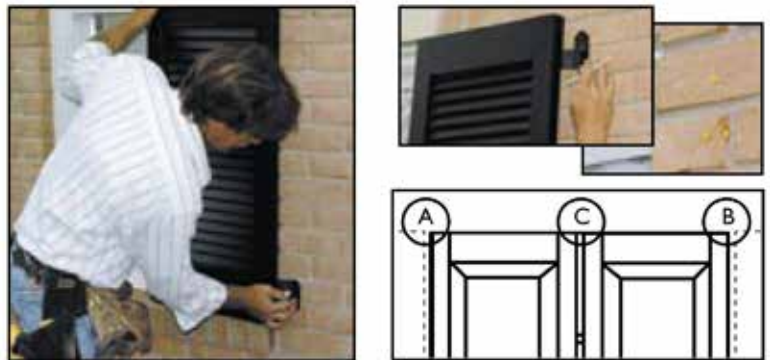

6. Install acorn clip. Swing shutter open and mark center of holdback clip. Install acorn clip into brick.



7. Install "S" Holdback.* The shutter is now held open by acorn anchor. Position shutter dog in correct location and mark for screws. Fasten to wall—1¾" down from shutter and 1¾" from outside edge.

**The acorn clip is better suited for holding the shutters in place, and as such, the "S" Holdback is recommended more for decorative use as opposed to a functional one.*



SHUTTER TERMINOLOGY

Beaded	A beaded detail that is molded into the inside edge of the face of each stile.
Board and Batten	Traditionally used on barns but ideal for more rustic homes. Authentic tongue and groove look with the front and back of the shutter featuring the same beveled look as if the shutter were made of individual boards.
Flat Panel	A solid shutter where the center portion of the shutter is recessed from the stiles.
Fixed Louvered	The louvers are tilted in towards the wall when the shutter is in the open position.
Leaf	A single shutter or 1/2 pair.
Mullions	The vertical element between the stiles that acts as a divider. Found in Bahama shutters.
Rabbeting	Also called "shiplap", used on many functional shutters. When closed, the shutter leaves fit into one another.
Radius or Arch Top	A shutter which has a curved top.
Rails	The horizontal crosspieces of a shutter (i.e. top rail, bottom rail, center rail).
Raised Panel	A solid shutter where the center portion of the panel protrudes outward from the surrounding routed bevel.
Shutter Capping	A metal (usually copper) capping that was placed over the top edge of the shutter to prevent water intrusion and the resulting wood rot. This capping is not necessary with Atlantic shutters as, due to materials used, they are impervious to both water intrusion and rot.
Stiles	The upright vertical sections of a shutter, which may be beaded or non-beaded.
Tilt Rod	Working louvered shutters have a rod, or tilt-rod, to move the louvers into the open or closed position. These are now non-functional, purely decorative for those who truly desire the more authentic look.